

November 12th Board Meeting



**Ronald McDonald
BUSTED
for not wearing
Covid mask . . .**





DISCOVERY: Haz Mat Survey/Mitigation

A variety of improvements and demolition may imply contact with hazardous materials, presumed to be limited to asbestos and lead-containing substances. *As such, the District intends to retain the selected environmental firm for an initial hazardous materials survey, abatement plan development, and potential execution of the abatement plans immediately prior to the beginning of construction [Clean Air Certificate required].*

K-3 Fire Station #31

“MITIGATION MOBILIZATION PLAN”

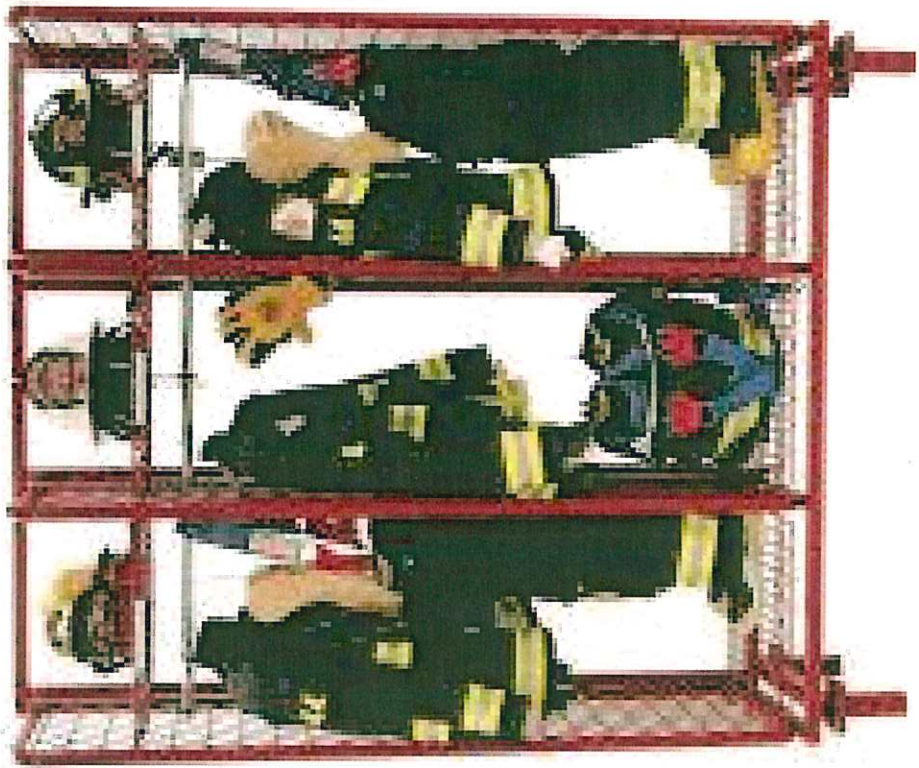

O.F.C.I

OWNER FURNISHED CONTACTOR INSTALLED

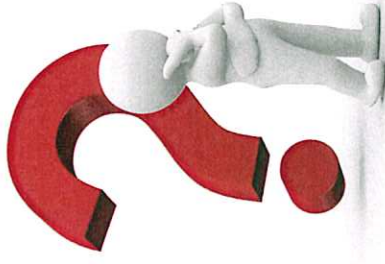
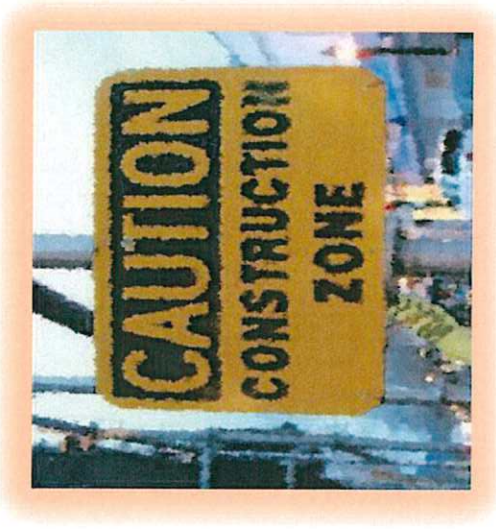

ITEM	Quantity	Details	Provider
ELECTRONICS			
Emergency generators			
Gen controls			
Fire/security systems			
IT/Data racks			
Telephone/intercom system			
Ops Base radios			
45' Base Radio Antenna Towers			
Station alerting sirens			
BUILDING EQUIPMENT			
Call boxes			
Station #32 apparatus doors/motors			
Digital display			
Decon extractor			
SCBA compressor			
Door locks			
Exhaust systems			
PPE racks/benches			
Hose racks			
White boards/cork boards			
Hanging racks			
Signage			
GROUNDS/SITE			
Propane tanks			
Landscaping			
APPLIANCES			
Kitchen refrigerator			
Kitchen stoves			
FURNITURE			
Meeting Room tables and chairs			
Ops Office chairs			
Ops map rack			



Emergency Call Box
2100-986DA
2100-986DAI

Station #31 and Station #32



FOUNDATION DETAILS

TOWER NUMBER	OVER-TURNING MOMENT (FT-LBS)	TOTAL SHEAR (LBS)	MAT WIDTH "W"	CONCRETE VOLUME (CU. YDS.)
25G	7000	500	4'-0"	2.4
45G	12300	1000	5'-3"	4.1
55G	22100	1600	6'-0"	5.3
45GSR/65G	53100	3500	7'-9"	8.9

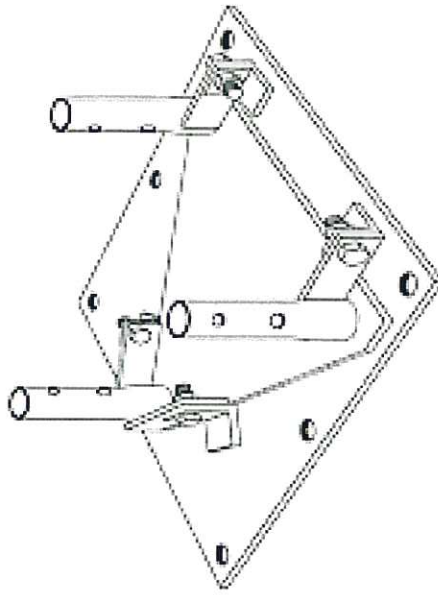
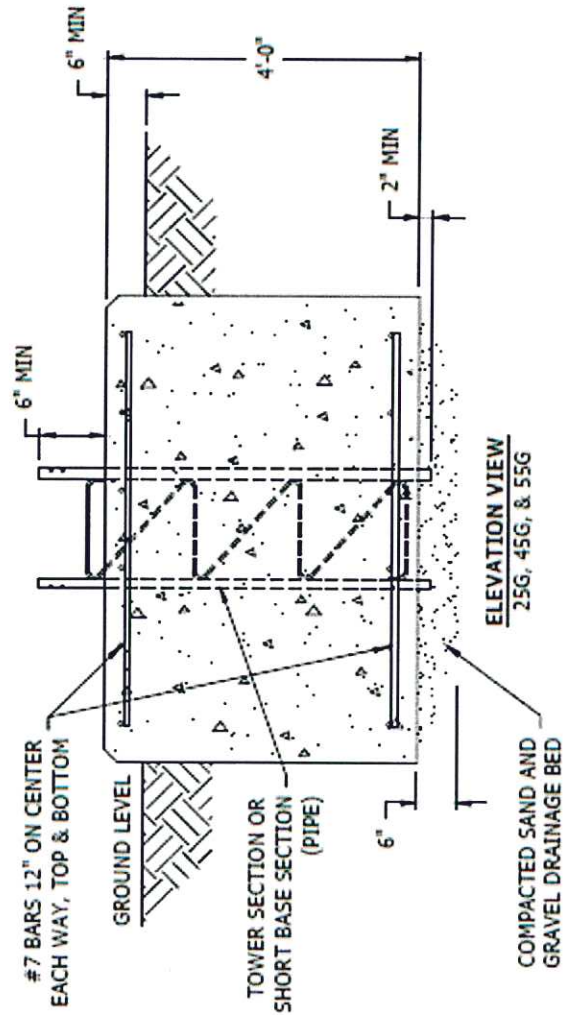
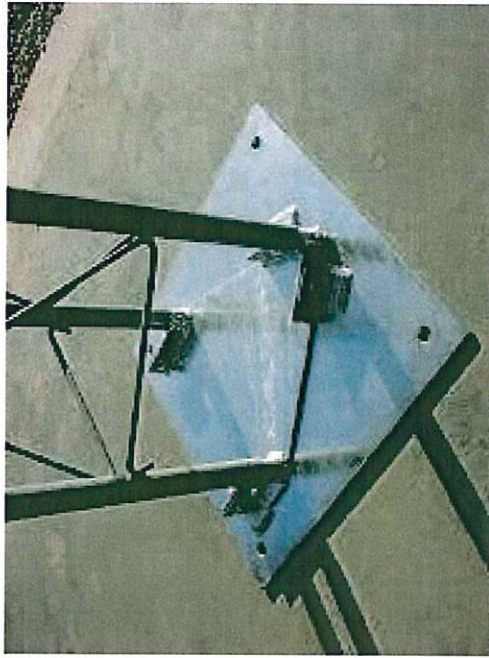

Building Mounted Digital Reader Boards

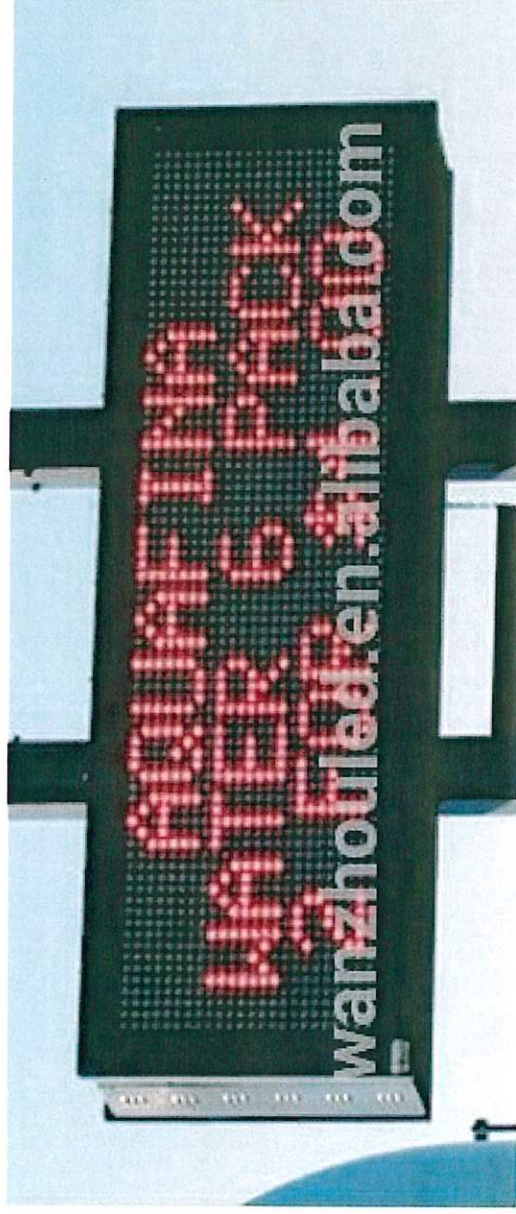



shutterstock · 195032606

TIMING

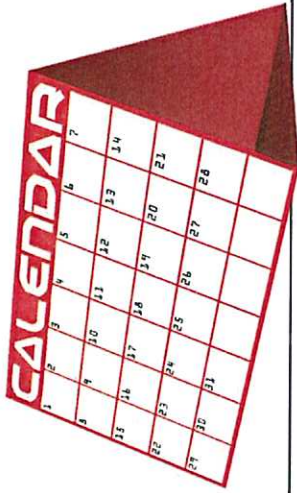

DISCOVERY
(Done)

Design &
Construction
Drawings

Haz Mat Survey &
Mitigation
(Clean Air Certificate)

Permits
Bids
Award



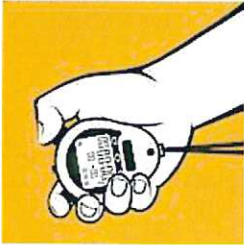

shutterstock - 195032606

TIMING



Status Update:

- I am beginning to receive final drawings from the consultants. I am actively working on finalizing my drawings and specifications relative to theirs for a coordinated construction/bid set.
- We're still working through the abatement plans with PBS and will be onsite tomorrow to go through specific details and scope on that front with them, some of which will need to be reflected in our drawings so there's a more accurate demolition scope for bidding contractors.
- Remaining items to button up before we can go to permit/bid are finalization of the plans of course, but also packaging the Division 00 and 01 specs for more general construction protocols contractors will need to follow, and
- also a well-rounded QC review of the set to make sure everything is well-stated. It's a process, and at the final stages it takes quite a bit of effort to bundle this all up and make sure everything is clear and enough is reflected for accurate competitive bidding.
- Drawings should be all done by some point next week, presuming there will be some things to incorporate from tomorrow's abatement meeting, and then I would say a reasonable target to submit for permit should be at the end of this month.



Washington Public Agency Contract Small Works, Consultant, and Vendor Rosters

This contract (the "Contract") is made by and between Municipal Research and Services Center of Washington ("MRSC"), a not-for-profit corporation, and the Washington local government (the "Public Agency"),

1. Purpose. The purpose of this Contract is to provide the Public Agency with membership in MRSC Rosters.
2. Scope of Services. MRSC shall host the entire Public Agency's individual Small Public Works Roster ("Small Works Roster"), individual Consultant Roster ("Consultant Roster"), and individual Vendor Roster ("Vendor Roster") (collectively "Rosters"). MRSC shall advertise at least annually for the Small Works Roster, Consultant Roster, and Vendor Roster in accordance with statutory requirements on behalf of the Public Agency. MRSC will assist small public works, consultant, and vendor business (collectively, "businesses") with roster registration throughout the year, receive applications, review applicant eligibility for compliance with basic statutory eligibility requirements, and maintain business applications in an online database.
3. Effective Date and Term. This Contract shall be effective in the year in which it is signed on either May 1 if signed prior to May 1 or December 1 if signed prior to December 1, for a period of one year.
4. Access to MRSC Rosters by Public Agency Prior to Legal Notice. As of the Contract effective date, the Public Agency may access the MRSC Rosters database at www.mrscrosters.org by entering its account login information, as will be provided by MRSC. The Public Agency may search for and view business applications as of the effective date of the Contract, but it may not contact businesses about roster projects until after the legal notice is posted.
5. Notification of Transition to MRSC Rosters. As of the contract effective date, the Public Agency may begin notifying interested businesses that they may register with the Public Agency at any time in the MRSC Rosters, but that the Public Agency will not begin using the hosted rosters until after the legal notice is posted.
6. Roster Legal Notice. MRSC shall post the statutorily-required roster legal notice on behalf of the Public Agency in a newspaper of general circulation relative to the location of the Public Agency. The notice will occur the first Monday of January or June, or during the week of the first Monday of January or June for weekly newspapers.
7. Use of MRSC Rosters by Public Agency. As of the date of the applicable legal notice in January or June, all departments of the Public Agency will discontinue use of any previously-maintained rosters and begin using the MRSC Rosters exclusively when choosing to follow a roster contracting process, in accordance with the following statutory requirements:
 - (a) Small Works Roster. The Public Agency will use the Small Works Roster to select businesses for public work projects in accordance with RCW 39.04.155, as now or hereafter amended. The Public Agency shall be responsible for its own and the selected businesses' compliance with all other laws and regulations governing public works contracting, including retainage and bonds, prevailing wages, and any other applicable requirements.
 - (b) Consultant Roster. The Public Agency will use the Consultant Roster to select businesses for consultant projects in accordance with the laws and ordinances applicable to the Public Agency, including Chapter 39.80 RCW when contracting for architectural and engineering services. The Public Agency shall be responsible for its own and the selected businesses' compliance with all laws and regulations governing the purchase of services.

(c) Vendor Roster. The Public Agency will use the Vendor Roster to select businesses to award contracts for the purchase of supplies, materials, and equipment not being purchased in connection with public works contracts in accordance with RCW 39.04.190, and any ordinances and other laws applicable to the Public Agency. The Public Agency shall be responsible for its own and the selected business' compliance with all laws governing such purchases.

8. Compensation of Businesses. The Public Agency shall be responsible for payments to any business that it selects as a result of its use of MRSC Rosters. The Public Agency shall make all such payments directly to the businesses selected by the Public Agency.

9. Annual Membership Fee. The Public Agency will pay MRSC an annual membership fee based on the five-year average of the Public Agency's total capital expenditures. Payment of the annual membership fee is due within thirty (30) days of the Contract effective date.

Based on the following Membership Fee Scale, the Public Agency will pay an annual membership fee of \$ _____.

Total Capital Expenditures	Annual Membership Fee
Less than 5 million	\$135
5 to 10 million	\$275
10 to 15 million	\$425
15 to 25 million	\$575
25 to 50 million	\$745
More than 50 million	\$1145

10. Relationship of Parties. MRSC will perform the services under this Contract as an independent contractor and not as an agent, employee, or servant of the Public Agency. Nothing in this Contract shall be construed to render the parties partners or joint ventures.

11. Limitation of MRSC Liability. MRSC shall not be, directly or impliedly, a party to any contract with small works, consulting, or vendor businesses which the Public Agency may enter into as a result of the Public Agency's use of the MRSC Rosters. MRSC does not accept responsibility or liability for the performance of any business used by the Public Agency as a result of its use of the MRSC Rosters.

12. Hold Harmless and Indemnification. Each party shall defend, indemnify, and hold the other party harmless from any and all claims, injuries, damages, losses, or suits, including attorney fees, to the extent arising from any negligent act or omission of that party's officers, employees, volunteers, and agents in connection with the performance of this Contract.

13. Termination. This Contract may be terminated, with or without cause, by written notice of either party to the other. Termination shall be effective thirty (30) days after written notice. Termination of the contract by the Public Agency does not entitle the Public Agency to a refund of the membership fee prorated as to the time remaining in the contract term following termination.

14. Renewal. This Contract may be renewed annually by completing the online renewal process that includes confirming that the Public Agency will continue abiding by the terms outlined in this Contract and making payment within thirty (30) days from the effective date of either May 1 or December 1.

15. Non-assignment. MRSC shall contract with Strategies 360 for the hosting of the Public Agency rosters in the online database. MRSC shall not otherwise subcontract or assign any of the rights, duties, or obligations imposed upon it by this Contract without the prior express written consent of the Public Agency.

16. Governing Law and Venue. This Contract shall be governed by the laws of the State of Washington.
17. Severability. Should any clause, phrase, sentence or paragraph of this Contract be declared invalid or void, the remaining provisions of this Contract shall remain in full force and effect.
18. Complete Agreement. This Contract constitutes the entire understanding of the parties. Any written or verbal agreements that are not set forth herein or incorporated herein by reference are expressly excluded.
19. Public Agency Information. For purposes of Contract administration, the Public Agency provides the following information:

Official Public Agency Name: _____

Common Public Agency Name (if different): _____

Mailing Address: _____

County: _____

Type of Public Agency: _____

Website: _____

Primary Contact:

Additional Contact:

Name: _____

Name: _____

Title: _____

Title: _____

Email: _____

Email: _____

Telephone: _____

Telephone: _____

Facsimile: _____

Facsimile: _____

20. Signatures. By signing this Contract, the Public Agency signatory below certifies that he/she has the authority to enter into this Contract on behalf of the entire Public Agency.

PUBLIC AGENCY

MRSC

[Signature]

[Signature]

[Title]

MRSC Rosters Manager
[Title]

[Date]

[Date]



Klickitat County Fire District 3

200 Husum Street – P.O. Box 151 Husum, WA 98623

(509) 493-2996

MRSC ROSTERS SMALL PUBLIC WORKS, AND CONSULTANT, and VENDOR ROSTERS RESOLUTION

Resolution No. 2015 -16

A RESOLUTION OF THE COMMISSIONERS OF KLICKITAT COUNTY FIRE DISTRICT 3, WASHINGTON, ON THE SUBJECTS OF ESTABLISHING A SMALL PUBLIC WORKS ROSTER PROCESS TO AWARD PUBLIC WORKS CONTRACTS, A CONSULTING SERVICES ROSTER FOR ARCHITECTIURAL, ENGINEERING, AND OTHER PROFESSIONAL SERVICES, AND A VENDOR ROSTER FOR GOODS AND SERVICES NOT RELATED TO PUBLIC WORKS CONTRACTS.

WHEREAS, RCW 39.04.155 and other laws regarding contracting for public works by municipalities, allow certain contracts to be awarded by a small works roster process; and

WHEREAS, Ch. 39.80 RCW and other laws regarding contracting for consulting services by municipalities allow certain contracts to be awarded by a consultant roster process; and

WHEREAS, RCW 39.04.190, regarding purchase of materials, supplies, or equipment not connected to a public works project, allows certain purchasing contracts to be awarded by a vendor roster process;

NOW, THEREFORE, THE COMMISSIONERS OF KLICKITAT COUNTY FIRE DISTRICT 3, WASHINGTON, HEREBY RESOLVES AS FOLLOWS:

Section 1. MRSC Rosters. The Fire Protection District wishes to contract with the Municipal Research and Services Center of Washington (MRSC) to have their official rosters hosted in the online database for Fire Protection District use for small public works contracts, and consulting services, developed and maintained by MRSC through MRSC Rosters and authorizes Fire Protection District Staff to sign that contract.

Section 2. Small Public Works Roster. The following small works roster procedures are established for use by the Fire Protection District pursuant to RCW 39.04.155:

1. **Cost.** The Fire Protection District need not comply with formal sealed bidding procedures for the *construction, building, renovation, remodeling, alteration, repair, or improvement of real property* where the estimated cost is over Twenty Thousand Dollars (\$20,000.00), but does not exceed Three Hundred Thousand Dollars (\$300,000.00), which includes the costs of labor, material, equipment, sales, or use taxes as applicable. Instead, the Fire Protection District may use

the Small Public Works Roster procedures for public works projects as set forth in this resolution. The breaking of any project into units or accomplishing any projects by phases is prohibited if it is done for the purpose of avoiding the maximum dollar amount of a contract that may be let using the small works roster process.

2. **Publication.** At least once a year, MRSC shall, on behalf of the Fire Protection District, publish in a newspaper of general circulation within the municipality's jurisdiction a notice of the existence of the small works roster and solicit the names of contractors for the small works roster. MRSC shall add responsible contractors to the small works roster at any time that a contractor completes the online application provided by MRSC, and meets minimum State requirements for roster listing.
3. **Telephone, Written, or Electronic Quotations.** The Fire Protection District shall obtain telephone, written, or electronic quotations for public works contracts from contractors on the appropriate small works roster to assure that a competitive price is established and to award contracts to a contractor who meets the mandatory bidder responsibility criteria in RCW 39.04.350(1). The Fire Protection District may establish supplementary bidder criteria under RCW 39.04.350 (2) to be considered in the process of awarding a contract.

- a) A contract awarded from a small works roster will not be advertised. Invitations for quotations shall include an estimate of the scope and nature of the work to be performed as well as materials and equipment to be furnished. However, detailed plans and specifications need not be included in the invitation.
- b) Quotations may be invited from all appropriate contractors on the appropriate small works roster. As an alternative, quotations may be invited from at least five contractors on the appropriate small works roster who have indicated the capability of performing the kind of work being contracted, in a manner that will equitably distribute the opportunity among the contractors on the appropriate roster. "Equitably distribute" means that the Fire Protection District may not favor certain contractors on the appropriate small works roster over other contractors on the appropriate small works roster who perform similar services.

If the estimated cost of the work is from one hundred and fifty thousand dollars (\$150,000) to three hundred thousand dollars (\$300,000), the Fire Protection District may choose to solicit bids from less than all the appropriate contractors on the appropriate small works roster but must notify the remaining contractors on the appropriate small works roster that quotations on the work are being sought. The Fire Protection District has the sole option of determining whether this notice to the remaining contractors is made by:

- (i) publishing notice in a legal newspaper in general circulation in the area where the work is to be done;
 - (ii) mailing a notice to these contractors; or
 - (iii) sending a notice to these contractors by facsimile or email.
- c) At the time bids are solicited, the Fire Protection District representative shall not inform a contractor of the terms or amount of any other contractor's bid for the same project;
 - d) A written record shall be made by the Fire Protection District representative of each contractor's bid on the project and of any conditions imposed on the bid. Immediately

after an award is made, the bid quotations obtained shall be recorded, open to public inspection, and available by telephone inquiry.

4. **Limited Public Works Process.** If a work, construction, alteration, repair, or improvement project is estimated to cost less than thirty-five thousand dollars (\$35,000), the Fire Protection District may award such a contract using the limited public works process provided under RCW 39.04.155 (3). For a limited public works project, the Fire Protection District will solicit electronic or written quotations from a minimum of three contractors from the appropriate small works roster and shall award the contract to the lowest responsible bidder as defined under RCW 39.04.010. After an award is made, the quotations shall be open to public inspection and available by electronic request.

For limited public works projects, the Fire Protection District may waive the payment and performance bond requirements of chapter 39.08 RCW and the retainage requirements of chapter 60.28 RCW, thereby assuming the liability for the contractor's nonpayment of laborers, mechanics, subcontractors, material men, suppliers, and taxes imposed under Title 82 RCW that may be due from the contractor for the limited public works project. However, the Fire Protection District shall have the right of recovery against the contractor for any payments made on the contractor's behalf.

The Fire Protection District shall maintain a list of the contractors contacted and the contracts awarded during the previous 24 months under the limited public works process, including the name of the contractor, the contractor's registration number, the amount of the contract, a brief description of the type of work performed, and the date the contract was awarded.

5. **Determining Lowest Responsible Bidder.** The Fire Protection District Commission shall award the contract for the public works project to the lowest responsible bidder provided that, whenever there is a reason to believe that the lowest acceptable bid is not the best price obtainable, all bids may be rejected and the Commission may call for new bids. A responsible bidder shall be a registered or licensed contractor who meets the mandatory bidder responsibility criteria established by Chapter 133, Laws of 2007 (SHB 2010) and who meets any supplementary bidder responsibility criteria established by the Fire Protection District.
6. **Award.** All of the bids or quotations shall be collected by the Chief or his designee.
 - a) The Chief or his designee shall then present all bids or quotations and their recommendation for award of the contract to the Commission. The Commission shall consider all bids or quotations received, determine the lowest responsible bidder, and award the contract; or
 - b) If the Commission delegates the authority to award bids to a Chief of the Fire Protection District for public works projects costing less than or equal to \$35,000, the Chief shall have the authority to award public works contracts without Commission approval, provided that the Commission shall ratify the Chief's approval at the next scheduled Commission meeting. For public works projects costing more than \$35,000, the Commission shall award all public works contracts.
7. **Posting.** A list of all contracts awarded under these procedures shall be posted at the Fire District's main administrative offices once every two months. The list shall contain the name of the vendor awarded the contract, the amount of the contract, a brief description of the items purchased, and the date it was awarded.

Section 4. Consulting Services Roster. The following consulting services roster procedures are established for use by the Fire Protection District pursuant to RCW 39.80.030:

1. **Consulting Services.** Consulting services are professional services that have a primarily intellectual output or product and include architectural and engineering services as defined in RCW 39.80.020.
2. **Publication.** At least once a year, MRSC shall, on behalf of the Fire Protection District, publish in a newspaper of general circulation within the municipality's jurisdiction a notice of the existence of the consulting services roster and solicit the names of consultants for the consulting services roster. MRSC shall add responsible consultants to the consulting services roster at any time that a consultant completes the online application provided by MRSC, upload a Statement of Qualifications, and meets minimum State requirements for roster listing.
3. **Review and Selection of the Statement of Qualifications Proposals.** The Fire Protection District shall use the following process to select the most highly qualified Architectural or Engineering firm off of the Consulting Services Roster to provide the required services:
 - a) The Commission shall establish criteria that the Chief, or their designee, must consider in evaluating Architectural or Engineering firms for a given project. Such criteria shall include a plan to insure that minority and women-owned firms and veteran-owned firms are afforded the maximum practicable opportunity to compete for and obtain public contracts for architectural or engineering services. The level of participation by minority and women-owned firms and veteran-owned firms shall be consistent with their general availability within the jurisdiction of the Klickitat County Fire District 3.
 - b) The Chief, or their designee, shall evaluate the written statements of qualifications and performance data on file with the Fire protection District at the time that architectural or engineering services are required;
 - c) Such evaluations shall be based on the criteria established by the Commission; and
 - d) The Chief, or their designee, shall conduct discussions with one or more firms regarding anticipated concepts and the relative utility of alternative methods of approach for furnishing the required services.
 - e) The firm deemed most highly qualified by the agency to do the project will be selected.
4. **Award.**
 - a) The Commission considers the proposal received and awards the contract; or
 - b) If the Commission delegates the authority to award projects to a Chief of the Fire Protection District for consulting services costing less than or equal to \$35,000, the Chief shall have the authority to award contracts for consulting services without Commission approval, provided that the Commission shall ratify the Chief's approval at the next scheduled Commission meeting. For consulting services costing more than \$35,000, the Commission shall award all contracts for consulting services.

Section 5. Vendor List Roster. The following vendor list roster procedures are established for use by the Fire District pursuant to RCW 39.04.190:

1. **Purchase of materials, supplies, or equipment not connected to a public works project.** The Fire District is not required to use formal sealed bidding procedures to purchase materials, supplies, or equipment not connected to a public works project where the cost will not exceed \$10,000. The Fire District will attempt to obtain the lowest practical price for such goods and services. When the cost is above Ten Thousand Dollars (\$10,000) but below Fifty Thousand Dollars (\$50,000), the fire district may use the Vendor List Roster procedures for purchasing projects as set forth in this resolution.
2. **Publication.** At least twice per year, MRSC shall, on behalf of the Fire District publish in a newspaper of general circulation within the municipality's jurisdiction a notice of the existence of the vendor list roster and solicit the names of vendors for the vendor list roster. MRSC shall add responsible vendors to the vendor list roster at any time when a vendor completes the online application provided by MRSC, and meets minimum State requirements for roster listing.
3. **Telephone, Written, or Electronic Quotations.** The Fire District shall use the following process to obtain telephone or written quotations from vendors for the purchase of materials, supplies, or equipment not connected to a public works project:
 - a) A written description shall be drafted of the specific materials, supplies, or equipment to be purchased, including the number, quantity, quality, and type desired, the proposed delivery date, and any other significant terms of purchase;
 - b) The Chief or their designee, shall make a good faith effort to contact at least three (3) of the vendors on the roster to obtain telephone or written quotations from the vendors for the required materials, supplies, or equipment;
 - c) The Chief or their designee, shall not share telephone or written quotations received from one vendor with other vendors soliciting for the bid to provide the materials, supplies, or equipment;
 - d) A written record shall be made by the Chief, or their designee, of each vendor's bid on the material, supplies, or equipment, and of any conditions imposed on the bid by such vendor;
4. **Determining the Lowest Responsible Bidder.** The Fire District shall purchase the materials, supplies, or equipment from the lowest responsible bidder, provided that whenever there is reason to believe that the lowest acceptable bid is not the best price obtainable, all bids may be rejected and the Fire District may call for new bids.
5. **Award.** All of the bids or quotations shall be collected by the Chief or his designee. The Chief, or their designee, shall create a written record of all bids or quotations received, which shall be made open to public inspection or telephone inquiry after the award of the contract. Any contract awarded under this subsection need not be advertised.
 - a) The Chief or their designee shall then present all bids or quotations and their recommendation for award of the contract to the Commissioners. The Commissioners

shall consider all bids or quotations received, determine the lowest responsible bidder, and award the contract; or

- b) If the Commission delegates the authority to award bids to the Chief of the Fire District for materials, supplies, or equipment costing less than or equal to \$20,000, the Fire Chief shall have the authority to award vendor contracts without the Commissioners approval, provided that the Commissioners shall ratify the Chief's approval at the next scheduled Commissioners meeting. For materials, supplies, or equipment costing more than \$20,000, the Commissioners shall award all vendor contracts.

- 5. **Posting.** A list of all contracts awarded under these procedures shall be posted at the Fire Protection District's main administrative offices once every two months. The list shall contain the name of the vendor awarded the contract, the amount of the contract, a brief description of the items purchased, and the date it was awarded.

PASSED this 19th day of November, 2015 and signed in authentication of its passage this 19th day of November, 2015.

Chairman Commissioner Zoller.

Commissioner Riggelman.

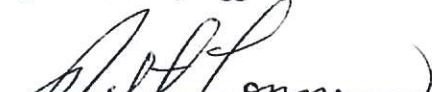
Commissioner Connor

ATTEST:

Secretary

APPROVED AS TO FORM:

Fire Protection District ATTORNEY